

SM1 and SM2 Programmers



The new Invensys SM1 single channel timeswitch and SM2 twin channel programmer gives style and ease of uses to suit most domestic pumped and gravity heating systems

Drayton SM1 and SM2

Features

- Single and dual channel
- Advance feature
- Modern styling
- LED indication
- 4 position slide (ease of setting)
- Intuitive time setting for ON/OFF
- Suitable for gravity and pumped systems
- Positive switching of time
- Two ON/OFF time functions per day
- All day option
- Universal industrial standard back plate

Wiring

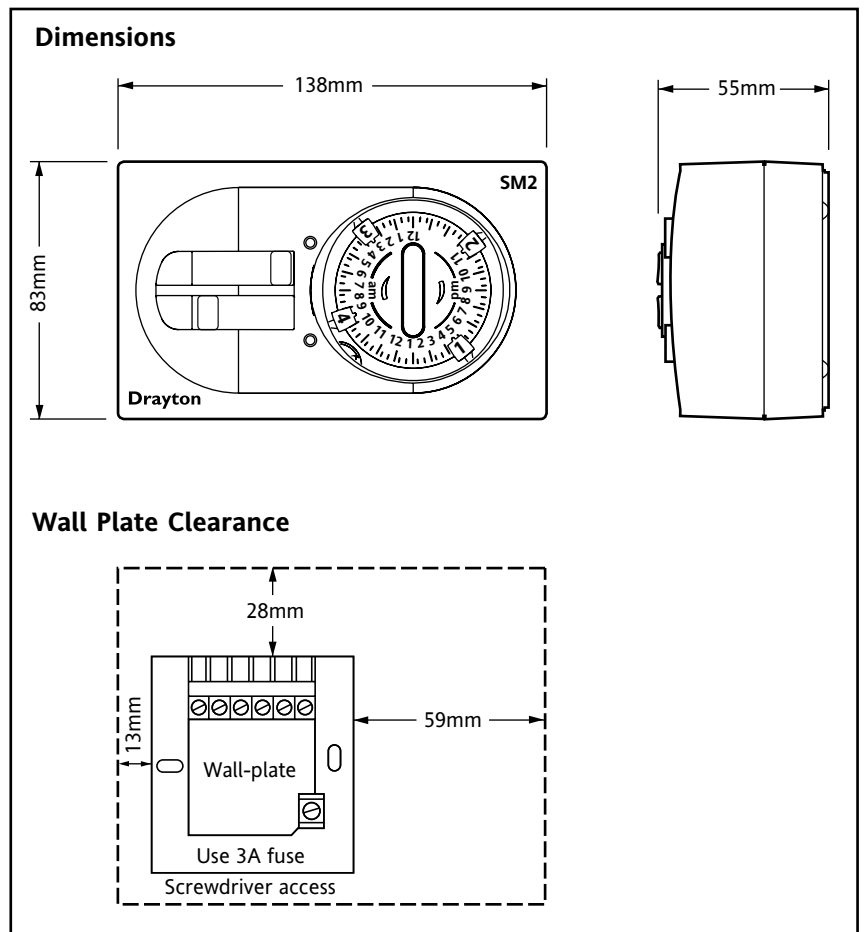
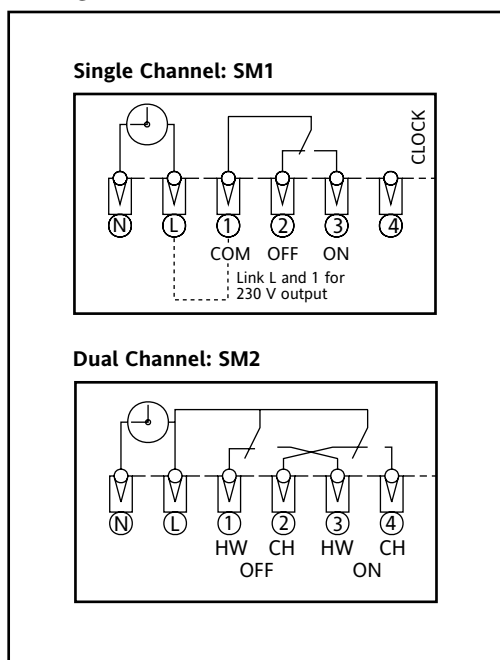

Technical data

Type	SM1 24 hour timeswitch SM2 24 hour programmer
Voltage	230V a.c.
Rating	2(1)A 230V a.c.
Ambient temperature	Operating: 0°C to 45°C Storage: 0°C to 50°C
Wiring	Designed for fixed wiring only to comply with the current I.E.E. regulations
Maintenance	No user maintenance should be attempted
Relevant EC Directives	2006/95/EC Low Voltage Directive 2004/108/EC Electromagnetic Compatibility Directive
Applied Standards:	EN60730-1; EN60730-2-9

Available from:

Invensys Controls Europe

Customer Service Tel: 0845 130 5522
 Customer Service Fax: 0845 130 0622
 Technical Helpline Tel: 0845 130 7722
 Email: customer.care@invensys.com
 Website: www.draytoncontrols.co.uk



D50-2